

- TABLE OF CONTENTS -

DOUBLE WALL SPECIFICATIONS

SECTION	PAGE	
1. APPLICABLE STANDARDS	PAGE	1
2. INFORMATION TO BE SUPPLIED BY CUSTOMER	PAGE	2
3. MATERIALS	PAGE	2
4. LAMINATE CONSTRUCTION	PAGE	3
5. LAMINATE DESIGN PHYSICAL PROPERTIES	PAGE	6
6. DESIGN REQUIREMENTS	PAGE	6
7. INSULATED TANKS	PAGE	8
8. TANK HEATING	PAGE	9
9. NAMEPLATE	PAGE	9
10. WORKMANSHIP AND LAMINATE QUALITY	PAGE	9
11. DIMENSIONS AND TOLERANCES	PAGE	10
12. HEAT CURE	PAGE	10
13. SURFACE CURE	PAGE	11
14. VISUAL INSPECTION	PAGE	11
15. WATER FILL TEST	PAGE	12
16. GENERAL	PAGE	12
17. FINAL INSPECTION	PAGE	12
18. SHIPPING	PAGE	12

1. APPLICABLE STANDARDS:

Unless otherwise agreed to between BELDING TANK TECHNOLOGIES and purchaser, the design, fabrication, testing, and installation of BELDING TANK TECHNOLOGIES storage tanks will meet or exceed the following industry standards:

A.S.T.M. D-3299-00 – Filament Wound Glass-Fiber-Reinforced Thermoset Resin Chemical-Resistant Tanks.

A.S.T.M. D-4097-00 – Contact Molded Glass-Fiber-Reinforced Thermoset Resin Chemical-Resistant Tanks.

Where applicable, provision from A.N.S.I./A.W.W.A. D120-84 – Thermoset Fiberglass Reinforced Plastic Tanks and A.S.M.E./A.N.S.I. RTP-1-1995 – Reinforced Thermoset Plastic Corrosion Resistant Equipment will be used.

Due to variations between the above specifications, many possibilities of design parameters are available. Design characteristics may be modified to suit. Consult with the factory for more specific details.

1.1 DESCRIPTION OF TERMS:

1.1.1 Definitions for most terms used within this standard are in accordance with A.S.T.M. D-883 Definitions of terms relating to plastics.

1.1.2 **FILAMENT WOUND** – The process in which the principle circumferential load bearing reinforcement is applied by continuous filament winding.

1.1.3 **CONTACT MOLDED** – A molding process that includes spray-up, hand lay-up, or a combination of those manufacturing processes.

1.1.4 **HEAD** – The end closure of cylindrical tanks (top or bottom).

1.2 TANK CLASSIFICATION – Tanks will be classified in the following manner:

Type I: Atmospheric pressure tanks vented directly to the atmosphere, designed for pressure no greater or lower than atmospheric.

Type II: Atmospheric pressure tanks vented directly into a fume conservation system, and designed to withstand the specified positive and negative pressure not to exceed 14 in. of water when all tie-down lugs are properly secured.

GRADE 1: (Premium) Tanks manufactured using a vinyl ester resin throughout.

GRADE 2: (Standard) Tanks manufactured using a vinyl ester resin in the corrosion barrier laminate and an isophthalic polyester resin in the structural laminate.

GRADE 3: (Economy) Tanks manufactured using an isophthalic polyester resin throughout.

GRADE 4: Tanks manufactured using a resin or resins other than B.T.T. Standard vinyl ester.

2. INFORMATION TO BE SUPPLIED BY CUSTOMER:

In order to properly design the storage tank for the service intended, the customer must supply the following information to BELDING TANK TECHNOLOGIES:

1. Any customer generated specifications that must be used.
2. Capacity.
3. Tank model designation.
4. Diameter – if critical.
5. Material to be stored in tank.
6. Temperature conditions.
7. Loading conditions – (i.e., seismic, snow, wind or agitator loads, external pressures (i.e. tank in dike), etc.)
8. Fittings and attachments to be provided, and their description.
9. Height, width and weight limitations.
10. Flange gasket and bolt materials.
11. Whether outside surface is to be pigmented.
12. Whether U.V. absorber is required in exterior resin.
13. Whether fire-retardant resins are to be used and the required maximum flame spread.
14. Whether tank is to be insulated. (see Section 7).
15. Type of heating system. (if required) (see Section 8).
16. Any special test procedures to be followed. (ie., hydrostatic test, acetone sensitivity, pressure, vacuum, etc.).

2.1 AGITATION:

To properly design tanks for agitator service, the customer must supply the following information to BELDING TANK TECHNOLOGIES.

1. Weight of agitator with shaft and propeller.
2. Downward load when running.
3. Maximum torque. (in/lbs).
4. Maximum bending moment. (in/lbs).
5. If agitator is top or side entering.
6. Agitator mount style and dimensions.

3. MATERIALS:

3.1 RESIN – The resins used shall be a corrosion resistant vinyl ester or isophthalic polyester thermo set resin that has been determined by previous documented service to be acceptable for the particular service conditions.

3.1.1 The resin shall contain no pigments, colorants, or fillers unless specified by the customer.

3.1.2 Ultraviolet absorber may be added to exterior resin layer if specified by the customer.

3.1.3 3-5% Antimony Trioxide may be added to halogenated resin in the structural laminate only, to increase the ignition resistance of the resin.

3.2 REINFORCEMENTS:

- 3.2.1 SURFACING VEIL – The inner surface reinforcement shall consist of either a synthetic fiber veil or a chemical resistant glass veil. The surfacing veil shall contain a coupling agent or binder that is compatible with the corrosion barrier resin. Veil thickness shall be 10 mil. minimum.
- 3.2.2 CHOPPED STRAND MAT OR GUN APPLIED CHOPPED STRANDS – shall be constructed from single-end type E-glass strands 1/2” minimum to 2” maximum length. The coupling agent or binder shall be compatible with the resin used.
- 3.2.3 CONTINUOUS ROVING – Filament winding requires a single-end type E-glass reinforcement with 250 yards/pound yield. The coupling agent or binder shall be compatible with the resin used.
- 3.2.4 WOVEN ROVING – Shall be minimum 24 ounces/square yard and compatible with the resin used.

4. LAMINATE CONSTRUCTION:

- 4.1 STRUCTURAL INNER TANK – The laminate comprising the structural tank (bottom head, sidewall, and top head) shall consist of four separate layers. These are the inner surface and the interior layer which make up the corrosion barrier, the structural layer, and exterior surface.
 - 4.1.1 INNER SURFACE – The inner surface exposed to the chemical environment shall be a resin rich layer .010 to .020 inch thick, reinforced with a surfacing veil. The glass content shall be 10% by weight maximum in this layer.
 - 4.1.2 INTERIOR LAYER – The interior layer shall consist of a resin rich laminate reinforced with chopped strands. The glass content shall be 27% +/- 5% by weight. The combined thickness of the inner surface and the interior layer shall not be less than 0.100 inch.
 - 4.1.3 STRUCTURAL LAYER:
 - 4.1.3.1 FILAMENT WOUND STRUCTURAL LAYER – Subsequent reinforcement shall be continuous strand roving. Glass content of the filament wound structural layer shall be 60% to 70% by weight. The thickness of the filament wound portion of the tank shell will vary with tank height (tapered wall construction). If additional axial strength is required, the use of chopped strands or unidirectional glass strands interspersed between wind layers is acceptable.
 - 4.1.3.2 CONTACT MOLDED STRUCTURAL LAYER – Subsequent reinforcement shall be comprised of alternating layers of chopped strands and such additional number of plies of woven roving to a thickness as required to meet the physical properties that are used for the design. Each successive ply or pass of reinforcement shall be well rolled prior to the application of additional reinforcement. All woven shall be overlapped 1”. Laps in subsequent layers shall be staggered at least 3” from laps in the preceding layer. All woven roving shall be followed by chopped strands without exception.

- 4.1.4 EXTERIOR LAYER – The exterior layer shall consist of a resin rich laminate reinforced with chopped strands. The glass content shall be 27% +/- 5% by weight. The thickness of the exterior layer shall not be less than 0.030 inch.
- 4.1.5 EXTERIOR SURFACE – The outer surface shall be coated with a resin rich layer for spill protection. Where air inhibited resin is exposed to air during cure, a full surface cure shall be obtained by coating the surface with a coat of resin containing 0.2% to 0.6% paraffin wax surfacing agent.
- 4.1.6 INNERSTITIAL SPACE – The tank shall have an interstitial space of 0.08 to 0.12 inch thick mesh with biplanar flow to allow product to gravity flow to the leak detection outlet.
- 4.2 STRUCTURAL OUTER TANK – The laminate comprising the structural outer tank (bottom head and sidewall) shall consist of four separate layers. These are the inner surface and the interior layer which make up the corrosion barrier, the structural layer, and exterior surface.
- 4.2.1 INNER SURFACE – The inner surface exposed to the chemical environment shall be a resin rich layer .010 to .020 inch thick, reinforced with a surfacing veil. The glass content shall be 10% by weight maximum in this layer.
- 4.2.2 INTERIOR LAYER – The interior layer shall consist of a resin rich laminate reinforced with chopped strands. The glass content shall be 27% +/- 5% by weight. The combined thickness of the inner surface and the interior layer shall not be less than 0.030 inch.
- 4.2.3 STRUCTURAL LAYER:
- 4.2.3.1 FILAMENT WOUND STRUCTURAL LAYER – Subsequent reinforcement shall be continuous strand roving. Glass content of the filament wound structural layer shall be 60% to 70% by weight. The thickness of the filament wound portion of the tank shell will vary with tank height (tapered wall construction). If additional axial strength is required, the use of chopped strands or unidirectional glass strands interspersed between wind layers is acceptable.
- 4.2.3.2 CONTACT MOLDED STRUCTURAL LAYER – Subsequent reinforcement shall be comprised of alternating layers of chopped strands and such additional number of plies of woven roving to a thickness as required to meet the physical properties that are used for the design. Each successive ply or pass of reinforcement shall be well rolled prior to the application of additional reinforcement. All woven shall be overlapped 1". Laps in subsequent layers shall be staggered at least 3" from laps in the preceding layer. All woven roving shall be followed by chopped strands without exception.
- 4.2.4 EXTERIOR SURFACE – The outer surface shall be coated with a resin rich layer for spill protection. Where air inhibited resin is exposed to air during cure, a full surface cure shall be obtained by coating the surface with a coat of resin containing 0.2% to 0.6% paraffin wax surfacing agent.

4.3 JOINTS:

- 4.3.1 The cured resin surfaces of parts to be joined shall be ground to expose the glass fiber reinforcement. The ground area shall extend beyond the lay-up areas so that no reinforcement is applied to an unprepared surface. The surface shall be clean and dry before lay-up. The entire ground area shall be coated with paraffinated resin after joint overlay is made.
- 4.3.2 The gap between bell and spigot joints shall be filled with a resin pour to eliminate any air pockets between the two pieces to be joined.
- 4.3.3 Highly filled resin putty shall be spread over the crevices and irregular shapes between joined pieces, leaving a smooth surface for lay-up.
- 4.3.4 The width of the first layer of joint overlay shall be 6" minimum. Successive layers shall increase 1" width minimum, to form a smooth contour laminate that is centered on the joint +/- 1/2 inch.

4.4 FITTINGS AND ACCESSORIES

- 4.4.1 The surfaces of fittings and accessories exposed to product shall have the same corrosion barrier laminate as outlined in section 4.1.1 and 4.1.2.
- 4.4.2 The cut edges of all laminates exposed to the product shall be sealed with the corrosion barrier laminate as outlined in 4.1.1 and 4.1.2. Where shape, thickness, or other restrictions preclude covering the edges with the corrosion barrier laminate, the edges shall be coated with paraffinated resin.
- 4.4.3 NOZZLE AND MANWAY INSTALLATION – follow the requirements of ASTM D-3299 or D-4097 for minimum installation standards.
- 4.4.4 NOZZLE AND MAYWAY CUTOUT REINFORCEMENT – Where a tank sidewall or head is cut in an area bearing hydrostatic pressure, the cutout reinforcing laminate shall not be less than two times the nominal nozzle diameter. For nozzles less than 6" diameter, the reinforcement diameter shall be the nozzle size plus 6".

4.4.4.1 CUTOUT REINFORCEMENT LAMINATE THICKNESS – The thickness of the cutout reinforcement laminate shall be determined using the following formula, but shall not be less than 1/4 inch.

$$Tr = 0.036 \times \gamma \times H \times D \times K / 2 Sr$$

WHERE:

Tr = Cutout reinforcement laminate thickness (in inches)

H = Height of liquid above nozzle.

K = 1.0 for nozzles 6 inch diameter and larger.

d = Nominal nozzle diameter (in inches).

Sr = Allowable tensile stress (not to exceed 10% of reinforcement laminate tensile strength).

γ = Specific gravity of product.

D = Tank nominal inside diameter (in inches).

K = (d/dr-d) for nozzles less than 6 inch diameter.

dr = Cutout reinforcement diameter (greater of 2 times d or d+6) (in inches).

This thickness (Tr), may be applied to the outer or inner surfaces, or be divided between them.

4.5 LEAK DETECTION AND VENT DRIER:

4.5.1 Tank(s) shall be supplied with leak detection with visual alarm module. The tank connection shall be a 1" F.N.P.T. coupling. Customer is to supply 110 VAC power supply to the alarm module.

4.5.2 Tank(s) shall be supplied with a vent drier to aid in eliminating moisture between the inner tank and the outer tank. The tank connection shall be a 2" F.N.P.T. coupling and FRP support bracket, when required, for customer supplied piping.

5. LAMINATE DESIGN PHYSICAL PROPERTIES:

BELDING TANK TECHNOLOGIES standard laminate design physical properties meet or exceed ASTM D-3299, ASTM D-4097 and ASME RTP-1 standards.

6. DESIGN REQUIREMENTS:

6.1 SIDEWALL – The minimum required wall thickness of the cylindrical straight shell at any fluid level shall be determined by using the following formula, but shall not be less than 1/4".

$$t = .036 \times \gamma \times H \times D / 2 \times Sh$$

WHERE:

t = Wall thickness in inches.

H = Fluid head in inches.

Sh = Allowable hoop stress in P.S.I. (see 6.1.1).

γ = Product specific gravity.

D = Tank nominal diameter in inches.

6.1.1 Allowable stress shall be determined using the following formula:

$$Sh = Et \times Z$$

WHERE:

ET = Tensile Modulus of laminate in hoop direction.

Z = Allowable strain (maximum allowable strain of the tank shall not exceed 0.001 inch/inch).

6.1.1.1 Allowable hoop stress (Sh) shall not exceed 1/10 of hoop tensile strength.

6.2 TOP HEAD – The minimum allowable head thickness shall be 1/4". The top head must be able to support a 250 pound load on a 16 square inch area without damage.

6.3 FLAT BOTTOM HEAD – Flat bottom heads shall be molded integrally with the straight shell portion of the tank, unless otherwise agreed upon. The perimeter of the tank bottom shall not have any variations from a flat plane that would prevent uniform contact with a properly prepared flat tank support pad when filled with liquid. The sidewall to bottom knuckle radius shall be not less than 1" for tanks 4' diameter & smaller and not less than 1 1/2" for tanks larger than 4' diameter.

6.3.1 **THICKNESS AND REINFORCEMENT** – The minimum thickness for a fully supported flat bottom head shall be 1/4” for 12’ diameter and smaller and 3/8” for greater than 12’ and up to 14’ diameter and shall include no less than 1 layer of woven roving reinforcement. The minimum thickness of the sidewall to bottom knuckle radius shall be equal to the combined thickness of the sidewall and bottom. The reinforcement of the knuckle radius area shall not extend beyond the tangent line of the radius and flat bottom, and shall extend up the tank sidewall a minimum of 8” for tanks less than 4’ diameter and 12” for tanks larger than 4’ diameter. The reinforcement will then taper into the sidewall for an additional length of 3” to 4”.

6.4 **ELEVATED DISHED BOTTOM HEAD** – Elevated dished bottom heads may be either molded integrally with the straight shell portion of the tank or molded separately using a bell and spigot joint for attachment to shell. The dished bottom head shall have a radius of curvature that is equal to or less than the tank nominal inside diameter.

6.4.1 **THICKNESS** – The thickness of the elevated dished bottom head shall be determined using the following formula, but shall not be less than 1/4”.

$$T_b = .885 (.036 \times \gamma \times H \times R) / S$$

WHERE:

T_b = Thickness (in inches)

γ = Product specific gravity.

H = Fluid head at deepest point (in inches).

R = Inside radius of dished head (in inches).

S = Allowable stress – (not to exceed 1/10 of laminate tensile strength) in pounds/square inch.

6.5 **SLOPE TANK BOTTOMS** – Shall conform to section 6.3 with the exception that the slope bottom may be molded separately from the straight shell.

6.6 **OPEN TOP TANKS** – Open top tanks shall incorporate a stiffening ring or flange. Additional stiffening may be incorporated into the design depending upon the intended use. Customer must advise fabricator of any equipment such as agitation, pumps, etc. causing external forces.

6.7 Above ground horizontal and rectangular tanks require special design considerations for each application and will not be considered in the design portion of this specification. However, all other portions of this specification apply to the above tank configurations.

6.8 **JOINTS** – Joints between sidewall sections and for attachment of top heads or bottom heads shall conform to the width and thicknesses as specified in ASTM D-3299 or ASTM D-4097 as a minimum.

6.9 **FITTINGS:**

The corrosion barrier of tank nozzles shall be equivalent to the inner corrosion barrier of the tank they are installed in. Construction shall be as follows:

6.9.1 FLANGED NOZZLES – Dimensions for flanged nozzles shall be per chart. The nozzle shall be of hand lay-up construction. Press molded flanges attached to pipe with adhesive are not acceptable, except for the inner flange on a double flange nozzle.

Flange Size	Flange Face O.D. (Max.)	Bolt Circle	Bolt Hole Size	Flange Face Thickness	PSI Rating	Bolts
1"	4-3/4"	3-1/8"	5/8"	5/8"	125	4 - 1/2
1-1/2"	5-1/2"	3-7/8"	5/8"	5/8"	125	4 - 1/2
2"	6-1/2"	4-3/4"	3/4"	11/16"	125	4 - 5/8
2-1/2"	7-1/2"	5-1/2"	3/4"	3/4"	125	4 - 5/8
3"	8"	6"	3/4"	13/16"	125	4 - 5/8
4"	9-1/2"	7-1/2"	3/4"	15/16"	125	8 - 5/8
6"	11-1/2"	9-1/2"	7/8"	1"	100	8 - 3/4
8"	14"	11-3/4"	7/8"	13/16"	50	8 - 3/4
10"	16-1/2"	14-1/4"	1"	15/16"	50	12 - 7/8
12"	19-1/2"	17"	1"	1-1/16"	50	12 - 7/8

6.9.2 COUPLINGS, NIPPLES, PIPE STUBS – Shall be of filament wound or contact molded construction. Press molded fittings are not acceptable.

6.9.3 TOP AND SIDE MANWAYS – Shall be constructed per manufacturer's standards using hand lay-up construction and of the same materials as the tank they are installed in. Pre-fabricated press molded flat plate side manhole covers are not acceptable.

6.9.4 VENTS – Unless agreed upon in advance by BELDING TANK TECHNOLOGIES, all tanks shall be vented to prevent an internal pressure or vacuum. The vent must be of sufficient size to handle the flow displacement of all combined inlet or outlet nozzles.
NOTE: Tanks are not designed for improper Air Loading.

6.9.5 HOLD DOWN LUGS – Hold down lugs or plates shall be installed on all tanks. The size and number of hold down lugs shall depend on the wind, seismic, and other loads the tank will be subjected to during normal operation.

6.9.6 LIFTING LUGS – Shall be installed on tanks over 200 pounds weight unless otherwise specified.

7. INSULATED TANKS:

7.1 SIDEWALL INSULATION – 2 pound density foam insulation shall be used on tank sidewalls. Either pre-fabricated foam board or sprayed-on insulation is acceptable.

7.2 TOP OR BOTTOM HEAD INSULATION – Must conform to 7.1.

7.3 INSULATION CASING – The protective exterior casing over insulation shall be either contact molded or filament wound. The minimum allowable thickness for insulation casing shall be 1/8". The insulation casing resin shall contain a pigment to protect insulation from ultra violet rays.
Note: For minor cracks in the insulation case, an exterior expandable caulk may be used.

7.4 EXPANSION JOINT – To allow for differences in expansion between the tank and the insulation casing, one or more expansion joints must be installed in insulation casing. The expansion joint must allow free movement of tank and insulation casing and be sealed off from water infiltration.

8. TANK HEATING:

8.1 ELECTRICAL RESISTANCE HEAT TRACING – Wrapped-on electric resistance heat tape or banding is not acceptable because of the very difficult accessibility in case of a failure.

8.2 HEAT PANELS – Heat panels shall be used where external electrical heat tracing is specified. Each heat panel system shall use a product temperature control thermostat and a panel overheat thermostat to protect tank and contents from possible damage.

8.3 STEAM COILS – Hairpin type steam coils are acceptable. Follow manufacturer's recommendations for materials and installation procedures.

8.4 OTHERS – Immersable electrical bayonet and plate type heat systems are acceptable. Follow manufacturer's recommendations for materials and installation procedures.

9. NAMEPLATE:

Tank nameplate shall be constructed of FRP materials and located approximately 5' up from tank bottom where possible. The nameplate shall include the following information:

1. Serial number.
2. Customer.
3. Customer purchase order number.
4. Tank model.
5. Tank capacity.
6. Design pressure.
7. Specific Gravity
8. Service temperature.
9. Product.
10. Corrosion barrier veil.
11. Corrosion barrier resin.
12. Structural layer resin.
13. Date of fabrication.
14. Tank tag (If Specified by Customer).

9.1 WARNING TAG – A warning to avoid pipe strain on FRP fittings, use flexible connections.

10. WORKMANSHIP AND LAMINATE QUALITY:

10.1 GENERAL APPEARANCE – Tank should be uniform in color. Joints and matting ground fittings shall not be whited out from over catalization. On pigmented tanks color of matting on joints and fittings shall be matched as close as possible to the color of the tank exterior. There shall be no burrs or sharp edges on tank. No knots in filament winding. All cut or ground edges shall be coated with paraffinated resin.

10.2 INNER SURFACE – Shall be free of cracks, crazes and blisters.

10.2.1 PITS – (Craters in the laminate surface) no more than 10 per square foot. Pits must be less than 1/8 inch diameter and 1/32 inch deep, and shall be coated with paraffinated resin to avoid exposure to product and possible contamination.

10.3 INTERIOR LAYER – Shall be free of dry glass, burned areas and foreign matter.

10.3.1 ENTRAPPED AIR – (Bubbles or voids in laminate) no more than 10 per square inch and less than 1/16 inch in diameter.

10.4 STRUTURAL LAMINATE – See table Section 14, page 11.

11. DIMENSIONS AND TOLERANCES:

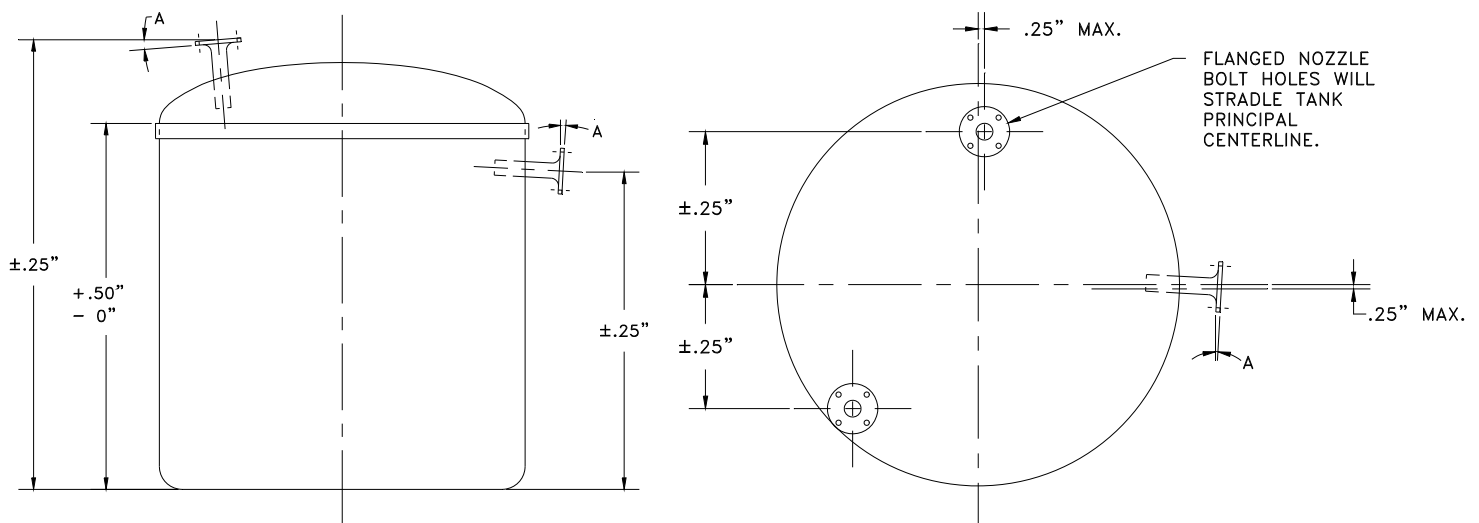

A = 1° for Nozzles 1" to 8" and 1/2° for Nozzles 10" and Up.

12. HEAT CURE:

12.1 FOOD GRADE TANKS – Tanks should be heated on the interior to a temperature of 180° to 200° F. and maintained for (4) hours. After tank installation and before putting the tank into service, attention to the following procedures is important to help achieve FDA compliance.

- (1) Steam-treat or steep it with hot water for 8 – 16 hours at 160° to 180° F. This should remove residual styrene from the interior surface.
- (2) Wash the tank with a mild detergent and rinse thoroughly.
- (3) Check state or local requirements in addition to the above recommendations.

12.2 POST CURE – When recommended by the resin manufacturer's corrosion guide, the tank be should be heated on the interior to a temperature of 180° F. to 200° F. and maintained for (4) hours to more completely cure the resin. See resin corrosion guide for specific environments requiring a heat cure.

13. SURFACE CURE:

13.1 BARCOL HARDNESS TEST – All tanks should have barcol hardness readings taken and recorded on Quality Control report. Ten readings will be taken on the clean, resin rich surface of the tank. The (2) high and the (2) low readings will be eliminated. The average of the remaining readings will be reported as the Barcol hardness of the tank. (Barcol hardness reading of 90% or better of resin manufacturer’s specified Barcol hardness for resin used is considered satisfactory).

Note: Synthetic veil will lower Barcol readings 5 to 10 points.

13.2 ACETONE TEST – Tanks requiring acetone test to check for proper cure should be tested as follows: Rub a small amount of clean Acetone on the laminate surface until the Acetone evaporates. If the surface stays dry and hard, it is properly cured.

CAUTION: Remove all mold release or paraffin wax and all dust from surface.

14. VISUAL INSPECTION CRITERIA (Ref. ASTM C-582, Section 9, Table 5):

DEFECT	SURFACE INSPECTED	
	CORROSION BARRIER	STRUCTURAL LAMINATE
Cracks	None	None
Crazing (fine surface cracks)	None	Maximum dimension 1". Maximum density 5/ft ² . ^A
Blisters (rounded elevations of the laminate surface over bubbles)	None	Maximum 1/4" diameter x 1/8" high, maximum 2/ft ² . ^A
Wrinkles & solid blisters	Maximum deviation, 20% of wall thickness, but not exceeding 1/8". ^A	Maximum deviation, 20% of wall thickness, but not exceeding 3/16". ^A
Pits (craters in the laminate surface)	Maximum dimensions, 1/8" dia. x 1/32" deep. Maximum number, 10/ft ² . ^A	Maximum dimension 1/8" diameter x 1/16" deep. Maximum density 10/ft ² . ^A
Surface porosity (pinholes or pores in the laminate)	Maximum dimensions, 1/16" diameter x 1/32" deep. Maximum number 20/ft ² by 1/16 in. Must be resin-rich. ^A	Maximum dimension 1/16" diameter x 1/16" deep. Maximum number 20/ft ² . Must be resin-rich. ^A
Chips (small piece broken from edge or surface)	Maximum dimensions, 1/8" diameter x 1/32" deep. Maximum number 1/ft ² . ^A	Maximum dimension 1/4" diameter by 1/16" deep. Maximum number 5/ft ² . ^A
Dry Spot (non-wetted reinforcing)	None	Maximum dimension, 2 in. ² . ^A
Entrapped air (bubbles, voids or delaminations in laminate)	Maximum diameter 1/16", 10/in. ² maximum density. Maximum diameter 1/8", 2/in. ² maximum density. Maximum depth of 1/32 in. ^{A,B}	Maximum diameter 1/16" 10/in. ² maximum density. Maximum diameter 1/8", 2/in. ² maximum density. Maximum diameter 3/16", 2/ft ² maximum density. ^{A,B}
Exposed glass	None	None
Burned areas	None	None
Exposure of cut edges	None ^C	None ^C
Scratches	None over 0.005 in. deep and 4 in. long	Maximum length 12". Maximum depth 0.010" 2/ft ² , maximum density. ^A
Foreign matter	None	1/8" diameter, maximum density 1/ft ² . 3/16" diameter, maximum density 1/ft ² . ^{A,D}

^A Maximum 5% of total surface area affected.

^B Entrapped air or bubbles described are allowed, provided the surface cannot easily be broken with a pointed object, such as a knife blade.

^C Maximum 5% of total surface area affected.

^D Maximum 5% of total surface area affected.

15. WATER FILL TEST:

Tanks requiring Water Fill testing should be filled to rated capacity. All water spilled or splashed on tank and surrounding area should be dried off. Tank should then be left standing for a minimum of 2 hours and checked for leaks.

16. GENERAL:

Specifications requiring independent laboratory tests shall be as outlined in ASTM D-3299 and ASTM D-4097.

17. FINAL INSPECTION:

Tanks shall be inspected for compliance with all applicable standards before being released for shipment. Detailed records of final inspection shall be kept in the job master file for future reference and certification of compliance with standard.

18. SHIPPING:

After final inspection, tanks are to be loaded on tank trailers or skids in such a manner as to prevent damage to flange faces and other fittings. BELDING TANK TECHNOLOGIES handling and installation instructions shall be provided to customer. Customer shall follow the instructions to insure proper handling and installation of tanks after delivery.